

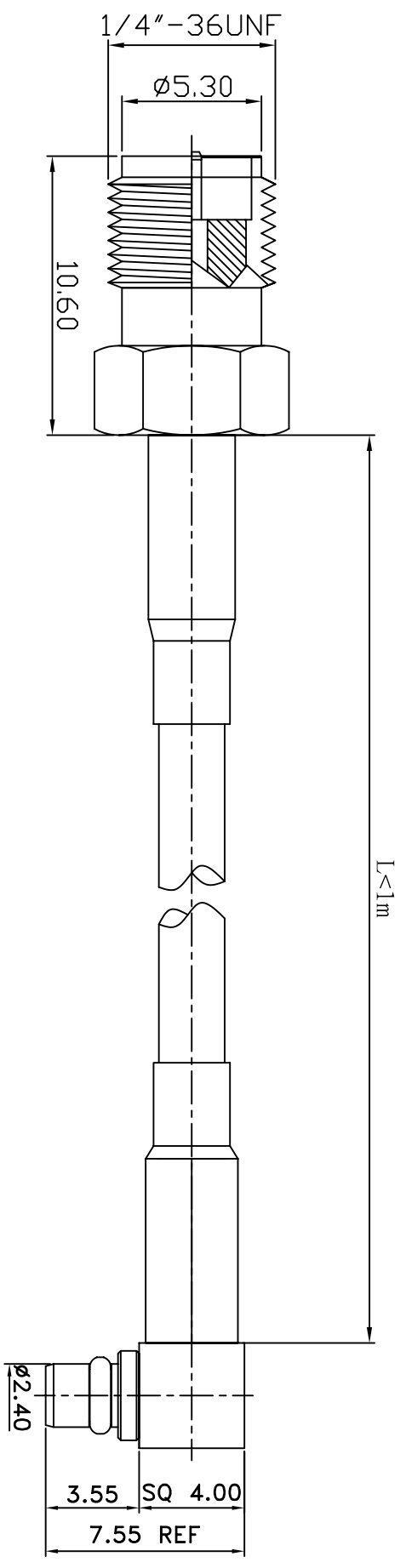

REV	DESCRIPTION	DRAWN	DATE



NO	Description	Qty	Material	Finish
3	MMCX-802-1-L-TGG	1	BRASS	GOLD
2	RG174/RG316/LLC100	1		
1	SMA-1011-2-RP-L-TGG	1	BRASS	GOLD

1 REMOVE ALL BURRS 2 BREAK ALL CORNERS & EDGES CO.15 MAX. 3 CHAMFER 15° & LAST THREADS 45°. 4 DIAMETERS ON COMMON CENTERS TO BE CONCENTRIC WITH DIMENSIONS ARE AFTER PLATING.		*MAJOR DIMENSION UNLESS OTHERWISE NOTED TOLERANCES 0.5-6=±0.2 6-30=±0.4 30-120=±0.6 120-315=±1.0 ANGLES=±1°		APPROVED CHECKED DRAWN ARNO		 華耀科技有限公司 Hua Yao Technologies co.,Ltd TITLE SMA1011-MMCX802 DRAWING NO. 8021/174/316/100/10112R-1L FILE NO. D:\DWG\SMA1011-MMCX802\8021/174/316/100/10112R-1L	
SCALE	4/1	UNIT	MM	DRAWN DATE	03/06/23	REV	A